

NO
BARRIERS



- Q. Why “NO BARRIERS”?
- A. Because there are no barriers to what we can do for our customers.

- Our culture of “NO BARRIERS” **empowers** our teammates and customers to take calculated risks; **enables** them to eliminate inefficiencies; and **inspires** them to solve problems – all resulting in mutual success.

INSPIRE. ENABLE. EMPOWER.

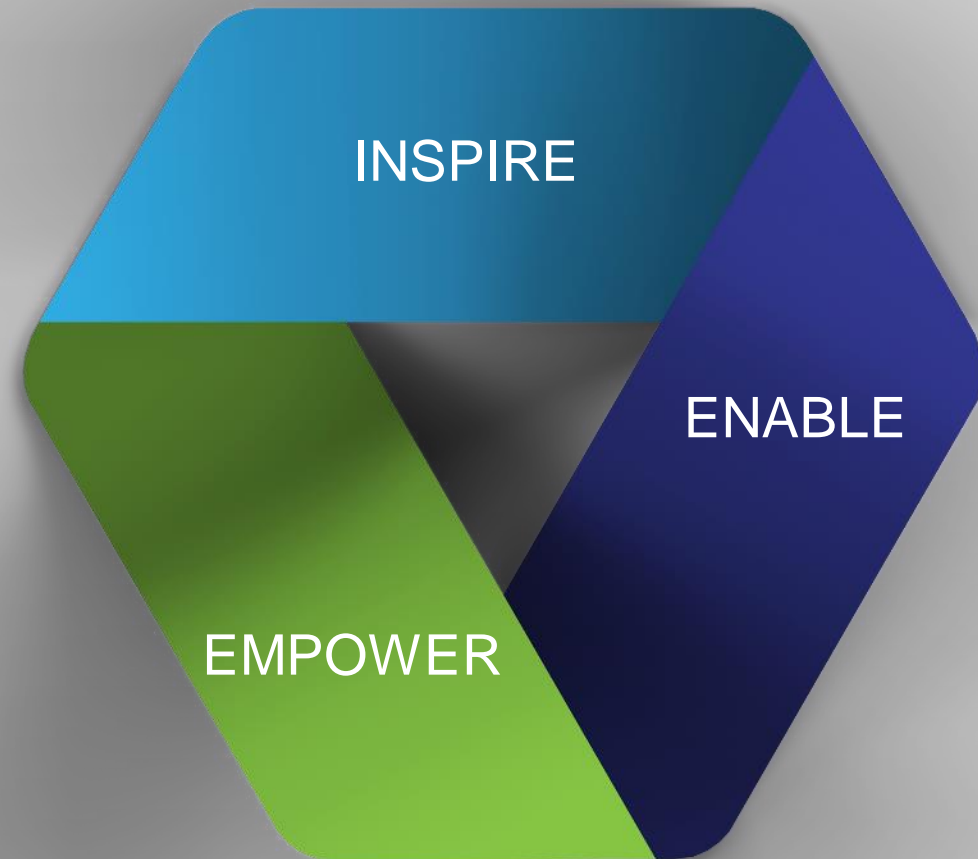

AT A GLANCE

- Innovex designs, manufactures and sells the most reliable and innovative products in the upstream oil and gas market.
- We provide high levels of service execution across the drilling, completion and production phases of our customers' wells.
- Our culture of “No Barriers” empowers our employees and customers to take risks, eliminate excuses, solve problems and drive success.
- Innovex has consistently outperformed the market over the last few years for a variety of reasons:
 - 🔹 Strong Team and Culture
 - 🔹 Excellent Customer Service
 - 🔹 Identifying customer needs and rapidly responding
 - 🔹 Cost effective manufacturing keeping pace with growth
 - 🔹 New product expansions



GENERATOR OF NEW CONTENT FOR THE INDUSTRY

- Proven and repeatable process for accelerating technology development and commercialization
- **27** R&D product development personnel with substantial industry experience within their respective product domains
- Manages a pipeline of new products in a balanced manner that fosters creativity while instilling discipline of time and resource allocation towards the most attractive opportunities
- **130+** granted and pending patents
- **47%** of Innovex 2019 annual revenue was derived from products developed since 2014

ROBUST PIPELINE OF NEW PRODUCTS

- It's critical to introduce new products during periods of industry stress
- Swage dissolving plug moved into full production mode
- Two new thru tubing tools in testing phase
- High value Deepwater product suite extensions scheduled for release this year (bundled with proprietary Wearsox offering)
- Evaluating two high margin greenfield product development initiatives that serve attractive, consolidated markets

Note: All figures pro forma for all acquisitions and net of any divestitures

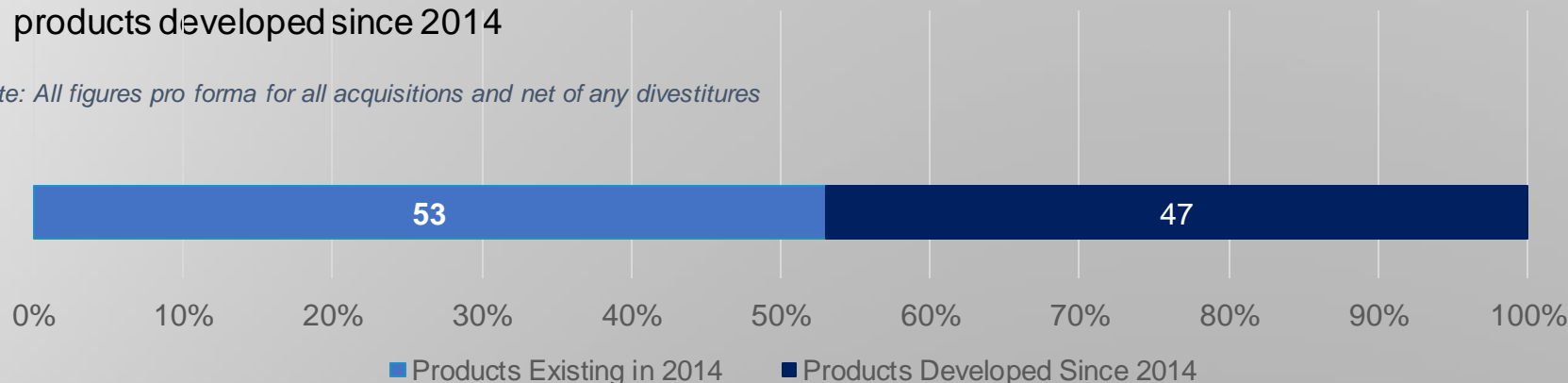

Approximately **47%** of Innovex's current revenue comes from new products commercialized since 2014

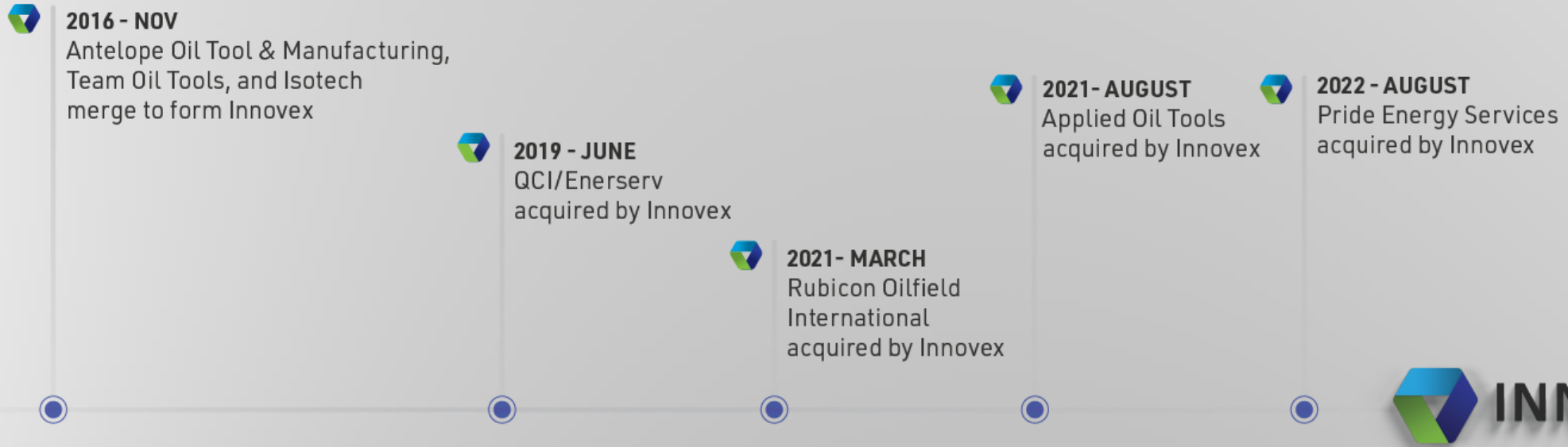



Company Overview

STRATEGIC GLOBAL FOOTPRINT

~1,000

EMPLOYEES
WORLDWIDE

5

MANUFACTURING
FACILITIES
WORLDWIDE

40

ADDITIONAL LOCATIONS
WORLDWIDE

316k

SQ. FT OF GLOBAL
MANUFACTURING



**HOUSTON HEADQUARTERS IS A 91,800 SQ FT FACILITY SUPPORTING ENGINEERING,
PRODUCT TESTING, MANUFACTURING AND BUSINESS SUPPORT FUNCTIONS**

**NO
BARRIERS**

ENHANCING OPERATIONAL EFFICIENCY ACROSS THE LIFECYCLE OF THE WELL

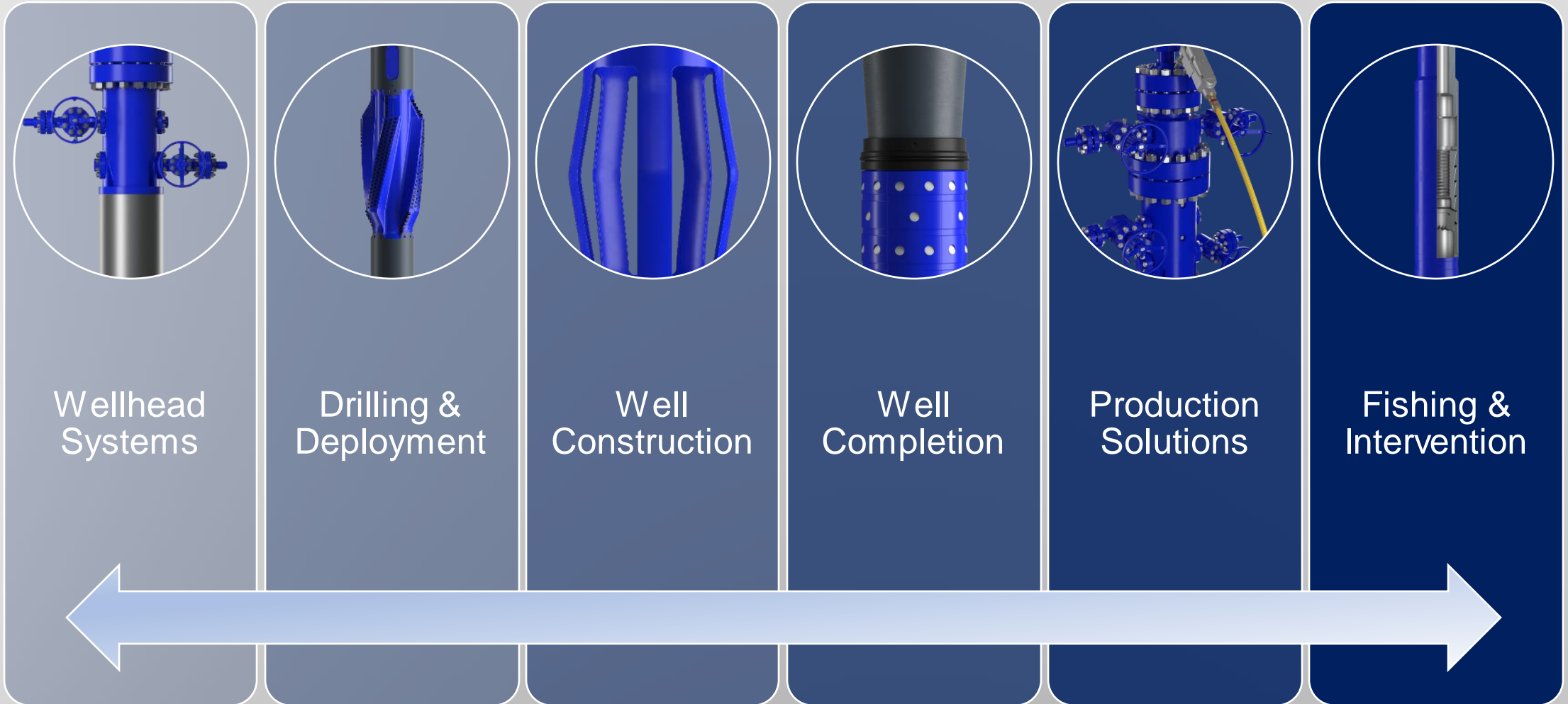

ALPHA WELLHEAD SYSTEM

Suspends casing and tubing.

Seals and isolates between casing at the surface.

Adapts connection between casing that leads to the wellbore and to the well control equipment (BOP) and rig.

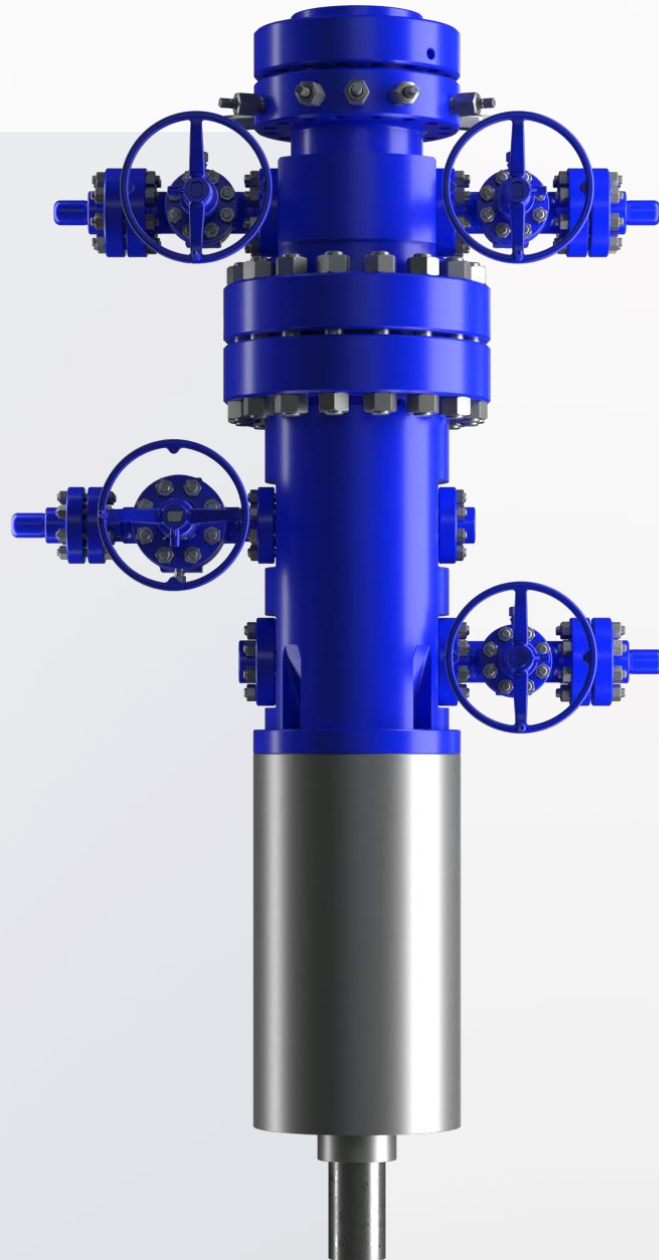

Wellhead Systems

- Quick disconnect for BOP NU/ND
- Rotatable mandrel casing hangers to assist getting casing to bottom
- BPV offers barrier for frac operations
- Internal lock ring eliminates leak paths of external lock screws and potential safety issues
- Compact, lower profile design that promotes safe handling during drilling operations
- Mandrel casing hangers and pack offs with positive lock down (contingency casing slips are available)
- Compatibility with offline cementing during pad drilling operations
- Reduces rig N/Us and testing
- Positive lock ring (biased inward)
- Single pack off for primary and contingency casing hanger
- Simple design & installation to avoid NPT
- Innovative engineered wash tool enhances successful installation (patent pending)
- Agile supply chain – availability of equipment
- Cost efficient

GUNDRILL REAMER

Uses the drilling BHA to improve hole shape, smoothness and quality, significantly reducing risk of borehole instability.

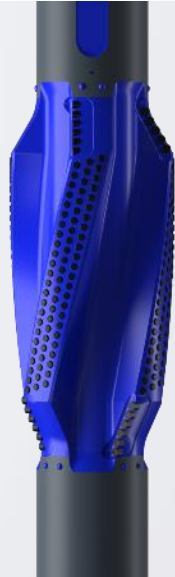

ROLLER GUNDRILL REAMER

Combines the advantages of the GunDRILL Reamer with the TorqAVENGER to improve hole quality and reduce casing/completions running times.



ECCENTRIC GUNDRILL REAMER

Enlarge hole while drilling and enhance wellbore quality for easier deployment of casing and elimination of wiper trips



TORQAVENGER

Provides stabilization by centralizing the BHA, minimizing downhole vibrations and reducing BHA fatigue.



VIBRATORY TECHNOLOGY

Delivering superior downhole friction reduction.

ResonATOR X3
Shake 'n' Bake



NO BARRIERS

Deployment Enhancement Products

SWIVELMASTER®

Resolves potential sticking & loss of hook load on drill strings by allowing the upper string to be rotated without rotation or torque to be transmitted to the BHA below.



CASINGSWIVEL

A permanent addition to the casing string that allows the upper casing section to be rotated independently from the lower section to reduce friction while running in hole.



TERRASWIVEL

A purely mechanical swivel with bearings suitable for moderate tensile & compressive loads.

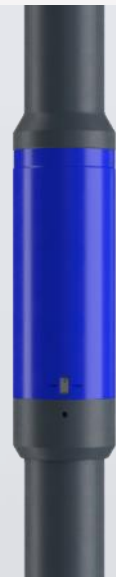

NAVISHOE

Increases probability of casings, liners and other open hole deployed systems reaching planned TD.



SUREREACH MOTOR SYSTEM

Working past ledges to avoid unnecessary NPT; this system is a cost-effective reaming method that is easy to use and does not complicate the final string installation.

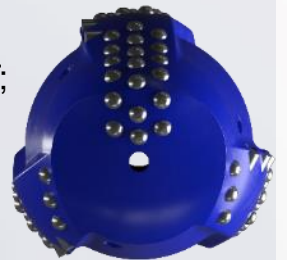

NO BARRIERS

CENTRALIZATION

Full suite of centralizers to reduce Torque & Drag, achieve optimal standoff and ensure proper cement placement for all well types.



CEMENTING PLUGS

Used during cementing operations for wiping the casing ID clean of drilling fluids and providing separation between mud, spacers, and cement.



WEARSOX THERMAL SPRAY

Patented WearSox® Thermal Spray for increased durability and wear resistance.



MULTI-STAGE CEMENTING

Reduces breakdown of weak formations due to high hydrostatic pressure from a tall column of cement and allows for effective zonal isolation around lost circulation zones.



FLOAT EQUIPMENT

Prevents back-flow while also serving as a landing point for wiping and displacement plugs.

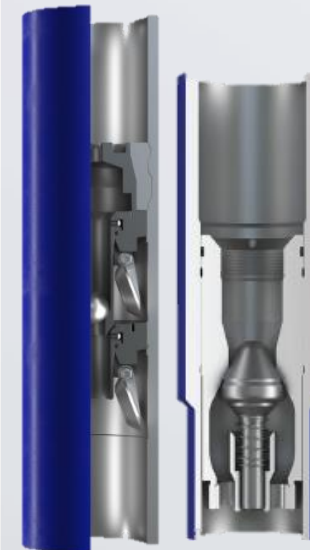

NO BARRIERS

LINER HANGER SYSTEMS

A range of liner hanger systems with options for every wellbore environment.



TOE SLEEVES

Both the traditional ORIO® and the metering ORIO® are designed specifically for a cemented environment.



PRODUCTION PACKERS

Simple and reliable Production Packers that have been proven in 1,000s of runs and can be configured to meet the needs of your specific application.



FRAC PLUGS

A proprietary frac plug to meet every wellbore environment. Each plug is 100% in-house designed and fully tested per industry standard procedures.



INFLATABLE CASING PACKERS

A comprehensive suite of zonal isolation solutions for global wellbore applications. Isolation performance in every application is optimized using standard and custom tools..



NO BARRIERS

WELLHEAD EQUIPMENT & SERVICES

A full line of 7-1/16" 3,000 psi to 15,000 psi wellhead completion solutions.

Hanger Completions
Adapters
Cover Plates
Frac Isolator



GAS LIFT

LiftSmart

The first and only cost-efficient, simple system featuring gas lift valves that operate independently of downhole and applied pressure.



SPOOLING

Capillary and CT equipment is customized and regularly maintained in order to bring you the highest level of efficiency and safety possible.

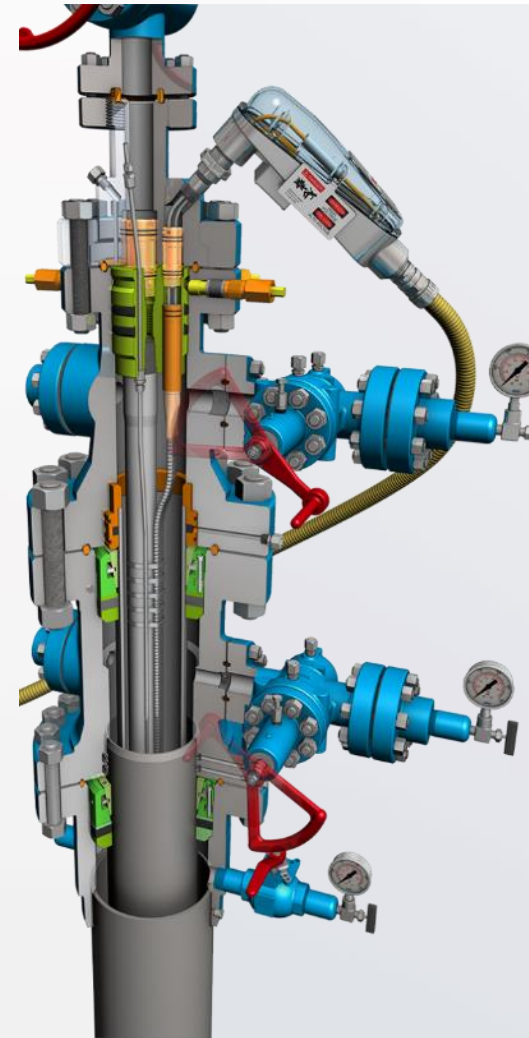

PENETRATORS & CONNECTORS

Designed specifically to meet or exceed electrical and API requirements for safety and performance. Systems are offered and listed by FM, FMc, IEC, IECEx, and ATEX, to ensure performance and reliability.

EXTERNAL CATCH

Overshots & Die Collars

Designed to engage, pack-off, retrieve most sizes of the fish and capable of releasing from the fish.



INTERNAL CATCH

Releasing Spears
Taper Taps
Spear Grapple
Assemblies
Packer Retriever Spear

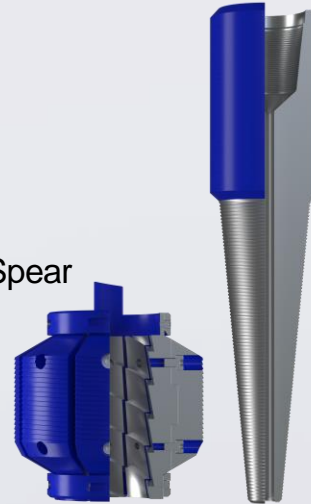

STROKING TOOLS

Coiled Tubing Jars
Energizers
Hydraulic Jars
Bumper Subs & Jars



JUNK CATCHERS

Junk Baskets
Magnets & Chargers
Junk Catcher
Assemblies
Lead Impression Blocks



Comprehensive line of fishing and intervention products provides for a variety of well workover, intervention, drilling, and completion activities.

REPAIR & REMEDIAL

Casing Scrapers
Casing Rollers
Casing Patches



MILLING & CUTTING

Junk Subs
Crossover Subs
External Cutters
Internal Cutters
Junk Mills



THANK
YOU

